



# **UniStar P**

## **6kVA, 8kVA & 10kVA**

**Tower Models**  
**SC60021T, SC60022T**  
**SC80021T, SC80022T**  
**SC11021T, SC11022T**

### **Parallel Redundancy/Capacity**

### **On-Line UPS**

### **User's Manual**

## **Table of Contents**

1.	Important Safety Instruction .....	2
1.1.	An Important Notice .....	2
1.2.	Storage Instruction .....	4
2.	Product Introduction .....	5
2.1.	General Characteristics .....	5
2.2.	Symbols on the LCD Display Panel .....	7
2.3.	Panel explanation .....	10
2.4.	Communication Port Explanation .....	13
3.	Installation and Operation .....	14
3.1.	Unpacking .....	14
3.2.	Selecting Installation Position .....	15
3.3.	Installation of Casters Cover .....	15
3.4.	Terminal Block Explanation .....	16
3.5.	Operation Test and Installation Instruction .....	18
4.	Troubleshooting Guide .....	30
4.1.	Trouble Shooting .....	30
5.	Bundled Software Installation Guide .....	32
5.1.	Hardware Installation .....	32
5.2.	Software Installation .....	32
6.	Customer Options Slots .....	33
6.1.	R2E(2nd RS-232 ) card .....	33
6.2.	RSE(RS-485) card .....	33
6.3.	USE(USB) card .....	33
6.4.	DCE(Dry Contact)-B card .....	34
6.5.	SNMP Cards .....	35
6.6.	The Installation of those Interface Cards .....	36
7.	Hot Swappable Battery Replacement .....	37
8.	Specifications .....	39

# 1. Important Safety Instruction

## 1.1. An Important Notice

1.1.1 For Parallel System installation, please refer to "Parallel System Installation Guide"

1.1.2 Because of "LITTLE LEAKAGE CURRENTS" generated by the EMI filter of the UPS, it is necessary to double ensure if the earth of the UPS is properly grounded before AC Mains is connected with.

1.1.3 To ensure safety in all applications where a UPS is hard wired to the Electrical Supply, ensure that the system is installed by a Qualified Electrical Contractor.

1.1.4 The UPS has its own internal energy source (battery). Should the battery be switched on when no AC power is available, there could be voltage at the output terminals.

1.1.5 Make sure that the AC Utility outlet is correctly grounded.

1.1.6 Do not open the case, as there are no serviceable parts inside. Your Warranty will be void.

1.1.7 Do not try to repair the unit yourself; contact your local supplier or your warranty will be void.

1.1.8 Make sure that the input voltage of the UPS matches the supply voltage.

1.1.9 Use a certified input power cable with the correct plugs and sockets for the appropriate voltage system.

1.1.10 To eliminate any overheating of the UPS, keep all ventilation openings free from obstruction, and do not store "things" on top of the UPS. Keep the UPS 30 cm away from the wall.

1.1.11 Make sure the UPS is installed within the proper environment as specified. (0-40°C and 30-90% non-condensing humidity)

1.1.12 Do not install the UPS in direct sunlight. Your warranty may be void if the batteries fail.

1.1.13 Install the UPS indoors as it is not designed for installation outdoors.

1.1.14 Dusty, corrosive and salty environments can do damage to any UPS.

1.1.15 Install the UPS away from objects that give off excessive heat and areas that are excessively wet.

1.1.16 If liquids are split onto the UPS or foreign objects dropped into the unit, the warranty will be null and void.

1.1.17 The battery will discharge naturally if the system is unused for any length of time.

1.1.18 It should be recharged every 2-3 months if unused. If this is not done, then the warranty will be null and void. When installed and being used, the batteries will be automatically recharged and kept in top condition.

1.1.19 This UPS supports electronic equipment in offices, telecommunications, process control, medical and security applications. Non-authorized technician is not allowed to install the UPS in the following areas.

- a. Medical equipment directly related to human life
- b. Elevator, Metro (Subway) system or any other equipment related to human safety.
- c. Public system or critical computer systems.

1.1.20 Do not install the UPS in an environment with sparks, smoke or gas.

1.1.21 Make sure the UPS is completely turned off when moving the UPS from one place to another. It might cause electrical shock if the output is not cut completely.

1.1.22 The Maintenance Bypass Switch is equipped with the UPS. Please follow the procedures strictly to switch on/off the Maintenance Bypass Switch.

1/1/23 The UPS offers CVCF (Constant Voltage Constant Frequency) setting function.

- a. For correct setting and wiring, please contact with your local agent.
- b. Do not do it by yourself; otherwise, your warranty will be void.

1.1.24 This UPS has been designed and constructed to protect your assets from the wide range of power aberrations experienced on Utility power lines today. It is your insurance for reliable, clean and stable voltage supply. It is worth taking care to install the system correctly and to have it maintained correctly by your local dealer.

1.1.25 SAVE THESE INSTRUCTIONS - This Manual Contains Important Instructions that should be Followed during Installation and Maintenance of the UPS and Batteries.

1.1.26 Intended for Installation in a Controlled Environment.

1.1.27 CAUTION - A disconnect switch shall be provided by others for ac output circuit. To reduce the risk of fire, connect only to a circuit provided with branch circuit over-current protection for 30 amperes rating in accordance with the National Electric Code, ANSI/NFPA 70.

1.1.28 CAUTION - To reduce the risk of fire, unit input connect only to a circuit provided with branch circuit over-current protection for 40 amperes rating in accordance with the National Electric Code, ANSI/NFPA 70.

1.1.29 Use No. 10 AWG, 60°C copper wire and 22.1 lb-in Torque force when connecting to terminal block.

## 1.2. Storage Instruction

For extended storage through moderate climate, the batteries should be charged for 12 hours every 3 months by plugging the UPS power cord into the wall receptacle and turn on input breaker on front panel. Repeat this procedure every 2 months under high temperature environment.

## 2. Product Introduction

### 2.1. General Characteristics

2.1.1 True online architecture continuously supplies in your critical device with a stable, regulated, transient-free pure sine wave AC Power.

2.1.2 20KHz PWM sine-wave topology yields an excellent overall performance. The high crest factor of the inverter handles all high-inrush current loads without a need to upgrade the power rating.

2.1.3 Multi-functional LCD/LED panel may display various status of the UPS. The LED display may show UPS working status, Utility Status and UPS Abnormal status, in the mean while, the LCD display may show Input/Output Voltage, Frequency, Load Status, Inner cabinet temperature, and Abnormal Phenomenon.

2.1.4 To protect the unit from overloading, it automatically switches to bypass mode in 160 seconds~40ms if loading is at 105%~150% of rating and in case of overloading at 150% of rating, it switches to bypass mode immediately. It will automatically switch back to inverter mode once overload condition ceases.

2.1.5 Should the output becomes short-circuit, the UPS holds the system and cuts the output automatically till the short circuit situation is removed manually.

2.1.6 Should the unit become overheated, the internal thermal Switch will detect the heat and switch to bypass mode and vice versa.

2.1.7 Fully digitalized control circuit built in the UPS may upgrade the functionality Of the UPS as well as reach a high-level protection of the UPS. Through powerful Communication capability built, it enhances its ability for remote control and monitoring easily.

2.1.8 Maintenance-free sealed-type battery minimizes after-sales service.

2.1.9 Maintenance bypass switch — it provides an easy and safe troubleshooting or maintenance function when the Utility is normal.

2.1.10 Providing four different working modes, such as Normal, ECO, CF50 and CF60, it may widely be used in a variety of applications.

2.1.11 DC-start function makes sure of the start-up of UPS during power outages.

2.1.12 Revolutionary battery management circuit analyzes battery discharging status to adjust battery cut-off point and extend the life of batteries.













2.1.13 Intelligent temperature-controlled fan may not only extend the life of the fan, but also reduce annoying noise because of sudden fan spin. It remains your office quiet and comfortable as usual.









2.1.14 When UPS is out of order, you may read out the possible fault reason from the LCD screen directly, which may reduce down unnecessary repair task a lot.

2.1.15 In case the UPS is out of order, Fault status will be shown on the LCD screen.

2.1.16 When the UPS is operated under CF50 or CF60 mode, the recommended load connected shall be 75% of rated capacity if the input voltage is 176~280Vac and 50% of the rated capacity if the input voltage is 160~280Vac.

## 2.2. Symbols on the LCD Display Panel

Item	Symbol	Description
1	LINE	Utility or Bypass Source
2		Battery Low
3		Battery Abnormal
4		UPS Overloading
5		UPS Working in specified mode*
6		A Blackout Transfer occurred in UPS Output
7		Bypass Input Abnormal, UPS fails to transfer to bypass, Bypass Abnormal at ECO mode
8		Utility Input Abnormal
9	OFF	UPS Shutoff
10	LINE    O    FF	UPS Abnormal Lock
11		UPS Flow Chart
12		4 Digits Measurement Display
13		Indicate the item desired to be measured
14		UPS ON Switch or Alarm Silence
15		UPS OFF Switch
16		Previous Page or Setting Change

17		Next Page
18		Special Function Log in /out
19		Enter or Reconfirmed
20		Utility Input Normal LED
21		Bypass Input Normal LED
22		UPS under Redundancy Mode
23		UPS under ECO Mode
24		UPS Fault or Abnormal Warning LED
25	<b>EPO</b>	Emergency Power Off
26	<b>Er05</b>	Battery Weak or Dead
27	<b>Er06</b>	Output Short Circuit
28	<b>Er10</b>	Inverter Over-current
29	<b>Er11</b>	UPS Overheat
30	<b>Er12</b>	UPS Output Overloading
31	<b>Er14</b>	Fan error
32	<b>Er15</b>	Wrong Procedure to enter Maintenance Mode
33	<b>Er16</b>	Output Parameters Set Error in Parallel System
34	<b>Er17</b>	ID Numbers are in conflict in Parallel System or ID number Error in single unit

35	<b>Er21</b>	Parallel communication error ( communication wire disconnected or failure to find ID1 UPS ) in parallel system
36	<b>Er24</b>	CVCF mode with Bypass input
37	<b>Er27</b>	The UPS must be operated in normal mode in parallel system
38	<b>Er28</b>	Bypass Overload Time out and cut off output.
39	<b>Er31</b>	The settings of both control board and driver board are not matched each other.
40	Er33	Isolated transformer overheat
41	<b>Er**</b>	Other Error code

*\*The specified modes include Normal mode, ECO mode, CVCF mode, etc..*

## 2.3. Panel explanation

### 2.3.1 Front Panel Function Explanations

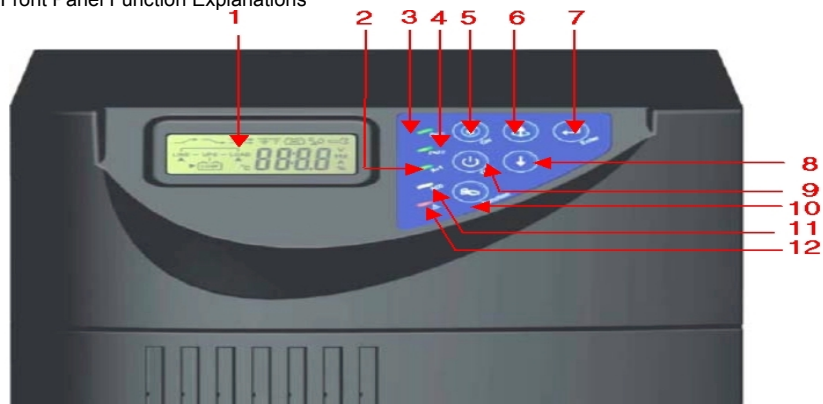

- ① LCD Display
- ② Green LED lights up to indicate the UPS has the capability to run under redundancy mode.
- ③ Green LED steadily lights up to indicate that the Utility input voltage is within the window; the LED flashes flickeringly to indicate that the Utility input voltage is within the acceptable window.
- ④ Green LED lights up to indicate Bypass Input is normal.
- ⑤ UPS ON/Alarm Silence
- ⑥ Go to previous page or change the setting of the UPS.
- ⑦ To re-confirm the change of UPS Setting
- ⑧ Go to next page
- ⑨ UPS OFF Switch
- ⑩ Special functions log in/out
- ⑪ UPS is working under ECO(Economic) mode.
- ⑫ UPS Fault or Abnormal

### 2.3.2 Rear Panel Explanation

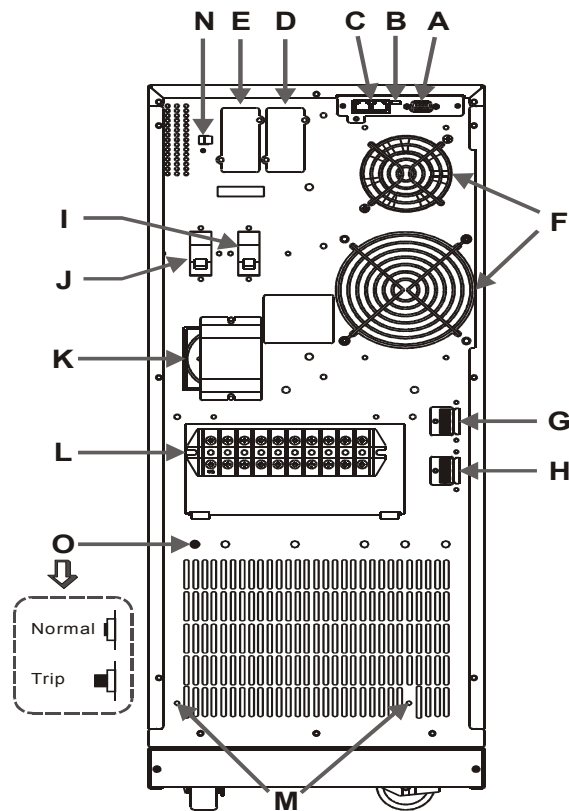

- A RS 232 Port
- B Terminal Resistor for Parallel function
- C CAN Bus Connection Port for Parallel System
- D Customer Options Slot 1
- E Customer Options Slot 2
- F Cooling Fan
- G External Battery Connector
- H External Charger Connector
- I Utility Input Breaker CB1
- J Bypass Input Breaker CB2 (for Dual Input Model Only)
- K CAM Switch(Maintenance Bypass Switch)
- L Input/Output Terminal Block

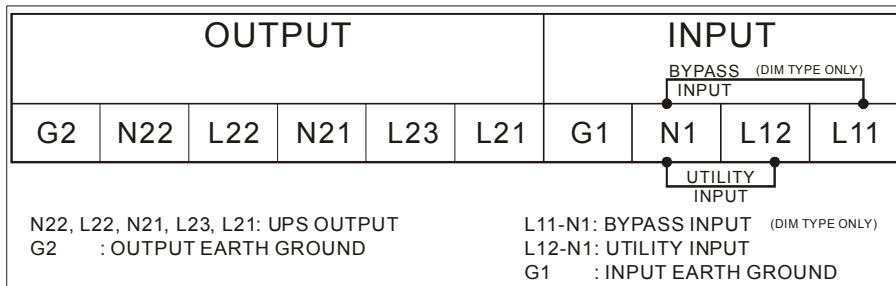

- M Fixing Holes for External Charger Cabinet
- N EPO ( Emergency Power Off ) : Short to enable the function
- O Thermal breaker for the protection of Load in abnormal condition:  
CB3

## 2.4. Communication Port Explanation

The Communication port on the UPS provides true RS232 type to communicate with UPS software to remote monitoring the power and UPS status.

With optional interfaces cards, which contains R2E (2<sup>nd</sup> RS232), RSE (RS485), USE (USB), DCE (Dry Contact), as well as SNMP/ card, you may combine them according to your demand. However, the R2E card, RSE card and USE card are prohibited to be used simultaneously.

The bundled software of the UPS is compatible with many operating systems such as Windows 98, & 2000, ME, NT and XP. For other applications like Novell, NetWare, Unix, Linux, please contact your local distributor for a proper solution.

When the optional interface cards are used together with onboard RS232 port in communication, the EPO signals will get the highest priority in control command, then the SNMP/WEB card, then the shutdown command at the DCE card & also R2E, RSE and USE, then onboard RS232 port get the lowest priority.

### 2.4.1 True RS232 type

#### 2.4.1.1. The RS232 interface settings

The RS232 interface shall be set as follows:

<b>Baud Rate</b>	<b>2400 bps</b>
<b>Data Length</b>	<b>8 bits</b>
<b>Stop Bit</b>	<b>1 bit</b>
<b>Parity</b>	<b>None</b>

#### 2.4.1.2. The Pin Assignments of true RS232 type

The Pin Assignments of true RS232 type are illustrated as follows:

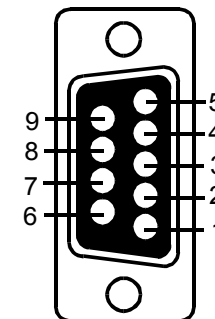

Pin 3: RS232 Rx  
 Pin 2: RS232 Tx  
 Pin 5: Ground

### 3.1 Installation and Operation

The packing condition and the external outlook of the unit should be inspected carefully before installation. Retain the packing material for future use.

#### 3.1.1 Unpacking

Take the UPS out of the PE foam.  
Unwrap the UPS.

Standard Package includes:

- 1 set of Quick Start Manual
- 1 set of User's Manual
- 1 set of UPS communication software with RS232 cable
- 1 set of Metal Accessories Kit as below:

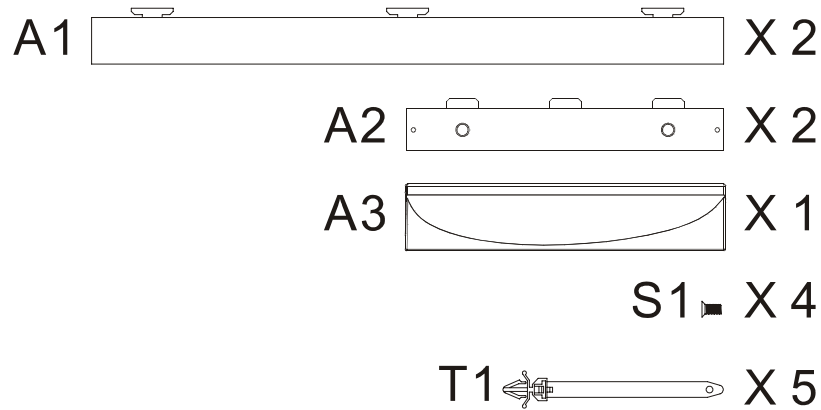

Package for the UPS with Isolation transformer:  
➤ with additional 3pcs wire No 7.

#### 3.2. Selecting Installation Position

It is necessary to select a proper environment to install the unit, in order to minimize the possibility of damage to the UPS and extend the life of the UPS. Please follow the advice below:

1. Keep at least 12 inches clearance from the rear panel of the UPS to the wall.
2. Do not block the air-flow to the ventilation openings of the unit.
3. Please check the installation site to avoid overheat and excessive moisture.
4. Do not place the UPS in an environment near dust, corruptive or salty material or flammable objects.
5. Do not expose the UPS to outdoors.

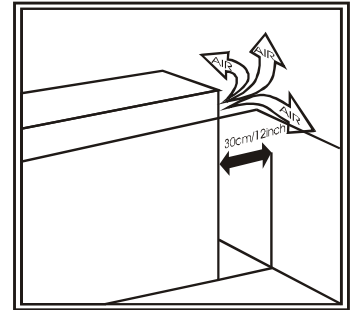

#### 3.3. Installation of Casters Cover

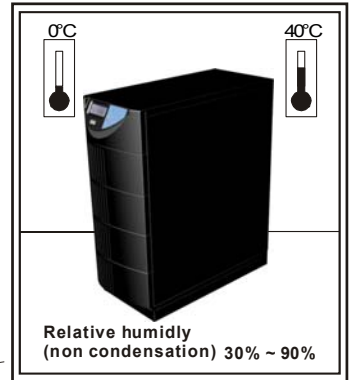
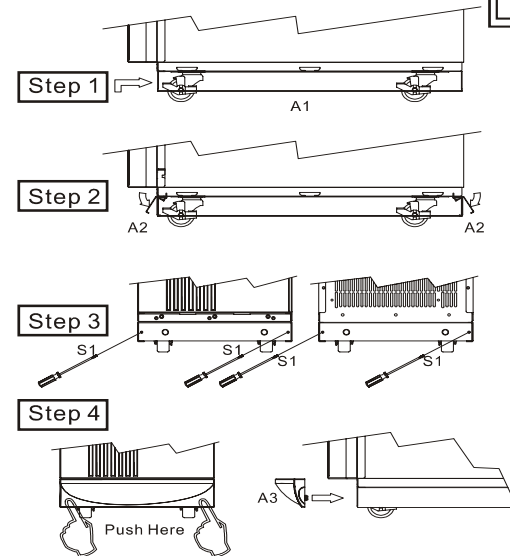



### 3.4. Terminal Block Explanation

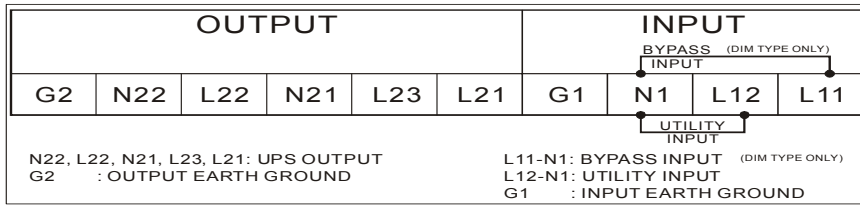

- **L11-N1**: the terminal for Bypass Input to provide the power source when the UPS is working under bypass mode.
- **L12-N1**: the terminal for Utility Input to provide the power source when the UPS is working under Utility mode.
- **G1**: the terminal for UPS Input Ground.
- **L21, L23, N21, L22, N22**: the terminals for UPS Output.
- **G2**: the terminal for UPS Output Ground.

#### Remarks:

1. Supply AC source to UPS from L12-N1 terminal.
2. When the Isolation transformer is NOT installed, the UPS output terminals will be L22-N22.
3. When the Isolation transformer is installed (standard unit):
  - a. For 100/110/115/120Vac system, you may connect as shown in below.

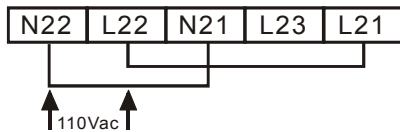

- b. For 200/100Vac, 220/110Vac, 230V/115Vac, or 240/120Vac, or 240/208/120Vac system, You may connect as shown in below.

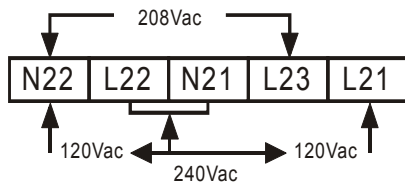

- Use Mounting Cable Tie to fix cables.

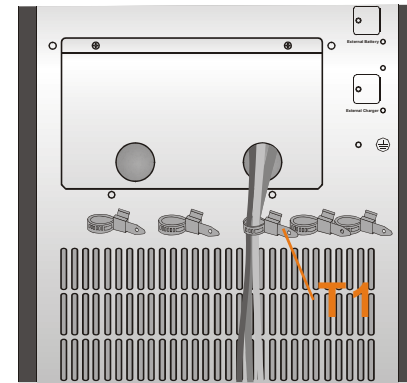

4. Please refer to the specs of input current, output current and recommended conductors listed as below:

#### a. AC input and output

Model	Maximum Current	Conductor Section
6KVA	33A	AWG #9
8Kva	54.3A	AWG #7
10KVA	54.3A	AWG #7

b.

#### Battery input

Model	Maximum Current	Conductor Section
6KVA	25A	AWG #10
8kVA	41A	AWG #10
10KVA	41A	AWG #10

### 3.5. Operation Test and Installation Instruction

#### Start Up in Normal Mode

- 3.5.1.1. Open the terminal block cover on the rear panel (refer to 0) Before start the installation, please make sure the grounding is connected properly.
- 3.5.1.2. Make sure Utility breaker, UPS' Utility breaker and Bypass breaker are On "Off" position.
- 3.5.1.3. Make sure the voltage of Utility matches with the input voltage window of the UPS.
- 3.5.1.4. Connect the Utility separately to the terminal blocks of UPS' Utility and Bypass Inputs. Switch on the Power Breaker of the distribution panel and the breakers of the UPS' Utility and Bypass Inputs, and then the UPS starts up. Green LEDs  $\approx 1$  &  $\approx 2$  light up to show the Utility and Bypass Inputs are normal and the LCD display with parallel function will illustrate from drawing A1, drawing A2 to drawing B. Otherwise the LCD display will illustrate from drawing A2 to drawing B.

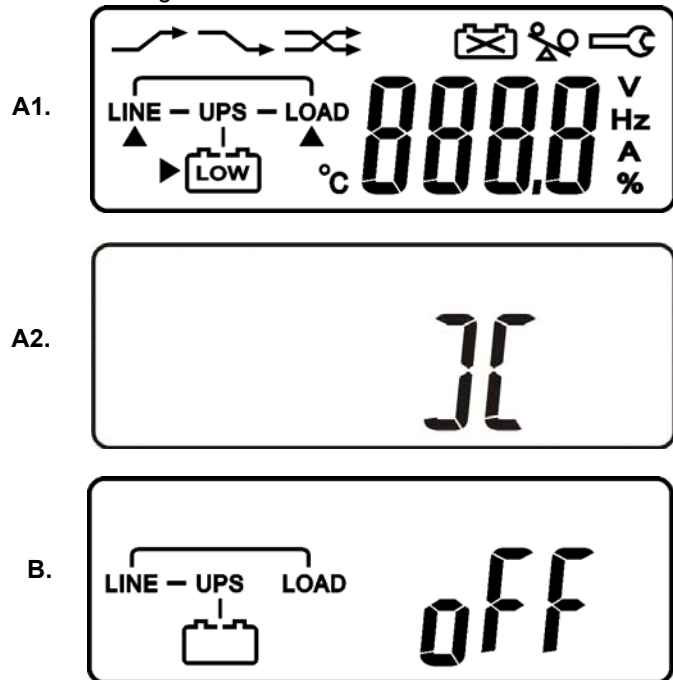

- 3.5.1.5. Then, the UPS is on Bypass Mode now and it will proceed self-test automatically. If there is no abnormal message occurred, it means the pre-startup of the UPS is successful and the charger starts to charge the batteries.
- 3.5.1.6. Press the UPS On Switch  for approx. 3 seconds, then the Buzzer sounds twice and the LCD display changes from drawing B to drawing C.

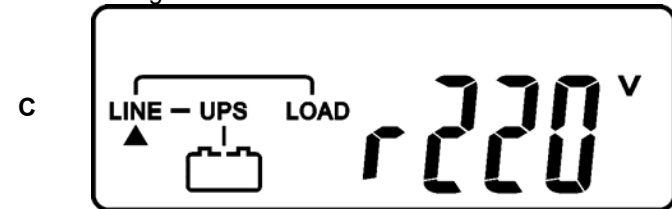

- 3.5.1.7. Then, the UPS is under self-test mode again, the LCD display will illustrate from drawing C to drawing D and remain approx. 4 seconds under battery mode, then illustrate from drawing E1 to drawing F if the self-test is successful.

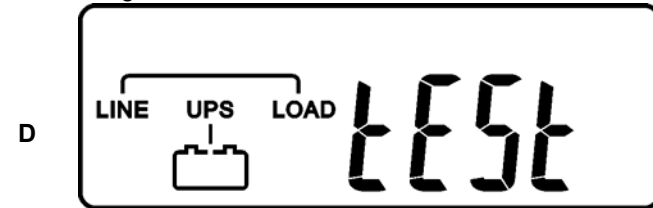

\* It shows "test".

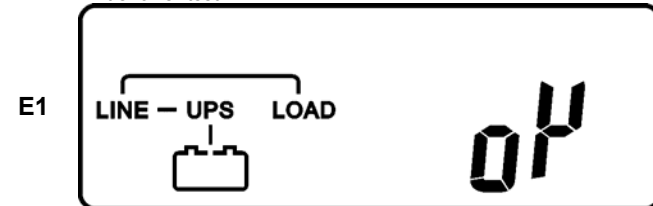

\* It shows "OK" in self-test

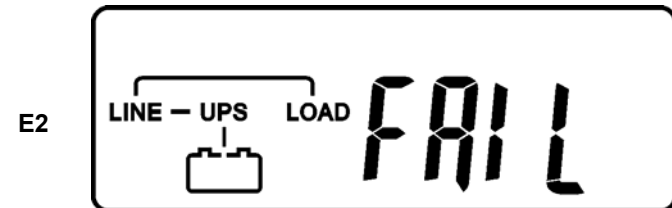

\* It shows "Fail" in self-test

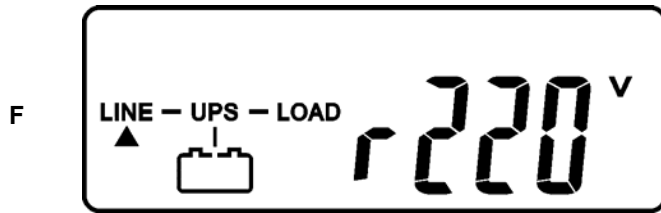

\* It shows "220Vac" in Utility Input.

- 3.5.1.8. In case of failure in self-test, the LCD display will illustrate from Drawing D to drawing E2, then an error code or error status will be shown on the screen.
- 3.5.1.9. Your start-up operation of the UPS is completely now. Make sure the UPS is plugged onto the wall receptacle for charging at least 8 hours and the batteries of the UPS are fully charged.

Start-up in Battery Mode (Cold Start)

- 3.5.1.10. Make sure the UPS you have has already been installed at least 1 set (20pcs) of 12V/7AH batteries.
- 3.5.1.11. Push the UPS On Switch (ⓘ) once for approx. 5 seconds to awake the UPS, and then the buzzer sounds twice. The LCD display will illustrate from drawing A to drawing G, and keep awake for approx. 15 seconds.
- 3.5.1.12. Press the UPS On Switch (ⓘ) of the UPS again for about 3 seconds till the LCD display illustrates from drawing G to drawing H, then the UPS will be in self-test Mode. The UPS may offer energy to the output in a minute, and the LCD display illustrates as drawing I. In case of failure in pushing the UPS On Switch within 15 seconds, the UPS will automatically turn off. You then have to go through step 3.5.1.10 to 3.5.1.12 once again.

3.5.1.13.

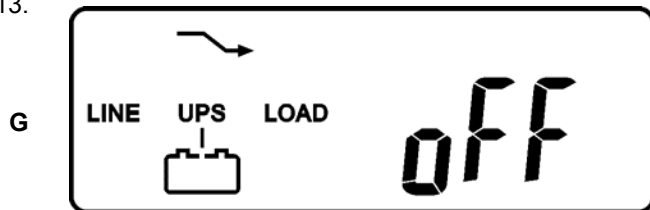

● It shows "Off", which means the UPS pre-start is successful.

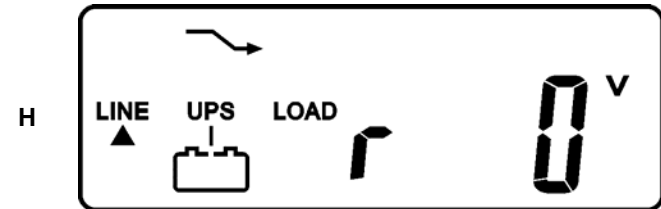

\* It shows Utility input is "0" and Utility Abnormal.

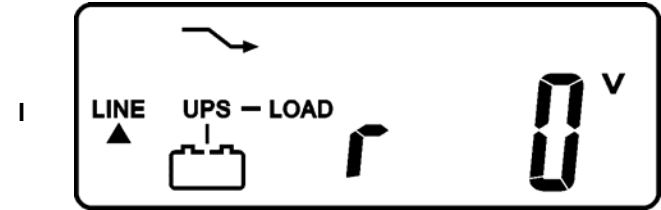

Check Measured Values & Figures detected by UPS

- 3.5.1.14. If you would like to check the measured values & figures detected by the UPS, please use scroll up (↑) and scroll down (↓) key pads. When you use scroll down key pad, the LCD display will illustrate as Drawing C(Voltage from Utility Input) → Drawing J(Frequency from Utility Input) → Drawing K(Frequency from Bypass Input) → Drawing L(UPS Output Voltage) → Drawing M(UPS Output Frequency) → Drawing N(UPS Output Load %) → Drawing O(UPS Battery Voltage) → Drawing P(UPS Inner Temperature).

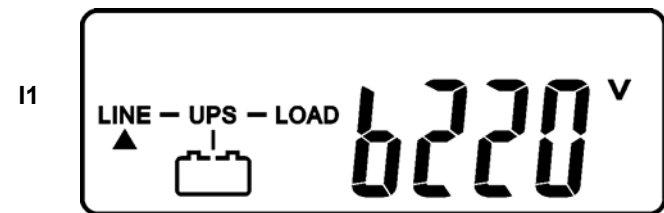

\* It shows voltage comes from Bypass Input

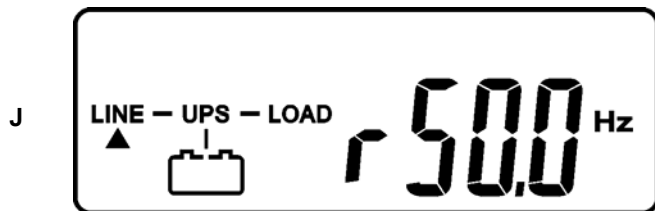

\* It shows frequency from Utility Input.

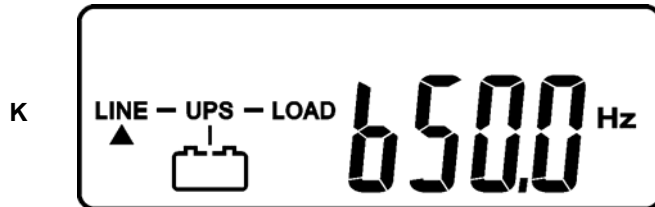

\* It shows frequency from Bypass Input.

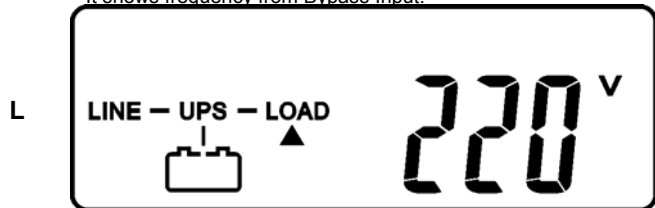

\* It shows UPS output Voltage.

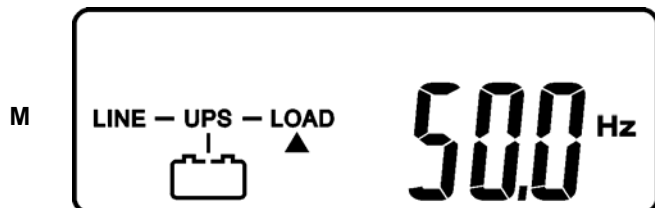

\* It shows UPS output frequency.

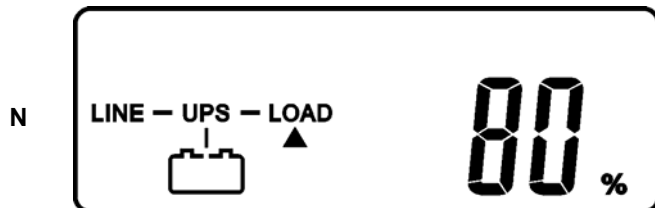

\* It shows UPS output load level(%)

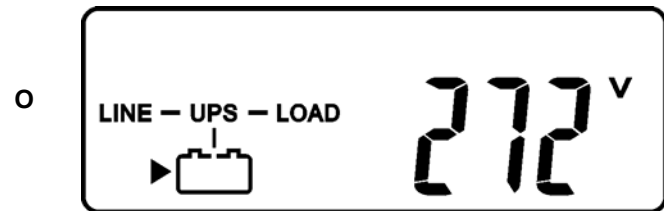

\* It shows Battery Voltage.

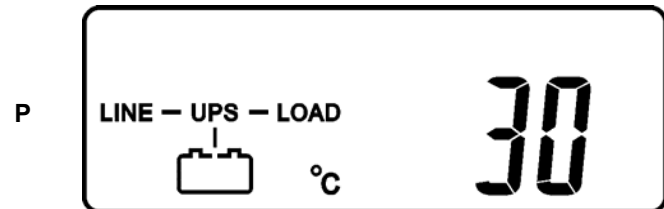

\* It shows UPS Inner Temperature

UPS Default Data and Special Function Execution

3.5.1.15. After UPS completely starts up, press key pad to change the LCD display screen to drawing Q1.

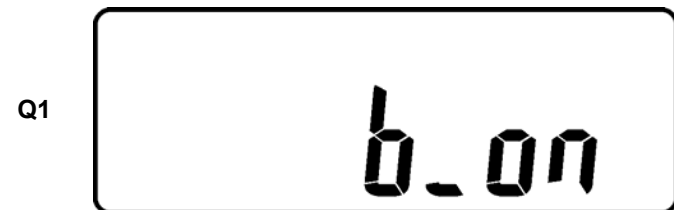

\* It shows buzzer "On".



\* It shows buzzer "Off".

3.5.1.16. Press  key pad to scroll down the screen and check the UPS settings. The LCD display will show in consequence between Drawing Q1(buzzer) → Drawing R1(Self-test) → Drawing S1(Bypass Voltage Windows) → Drawing T(Output Frequency Synchronization Window) → Drawing U(Inverter Output Voltage) → Drawing V1(UPS Operation Mode) → Drawing W(Output Voltage Micro Tune Value) → Drawing X(UPS Id) → Drawing Y(Parallel function status).

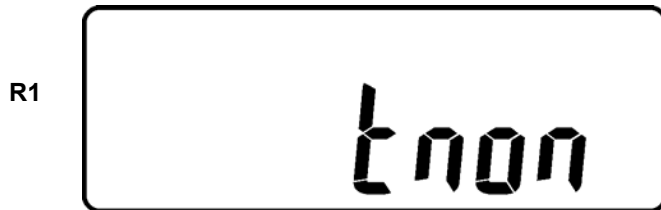

\* It shows self-test is NOT "on".

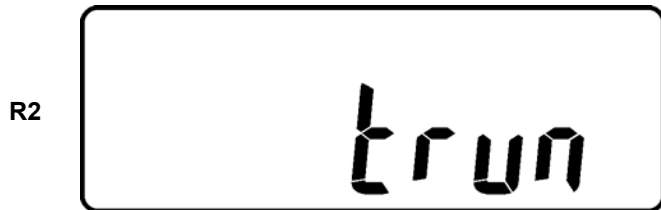

\* It shows self-test is "On".

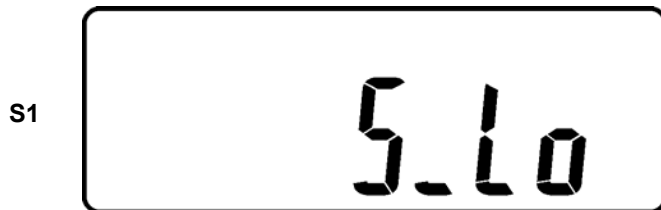

\* It shows Bypass Voltage is adjusted to narrow one.

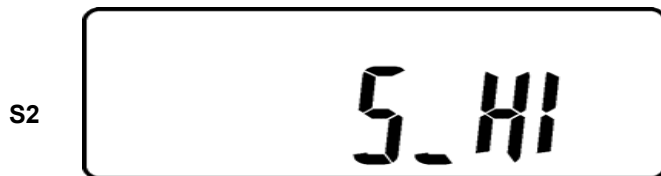

\* It shows bypass voltage is adjusted to wider one.



\* It shows Frequency Window is +/-3Hz.



\* It shows inverter output voltage.



\* It shows the UPS is operated in "normal mode".



\* It shows the UPS is operated in "Eco mode".



\* It shows the UPS is operated in "CVCF 50Hz mode".

V4



\* It shows the UPS is operated in "CVCF 60Hz mode".

W



\* It shows Output Voltage Adjustment % from 0% to 3% or -0% to -3%.

X

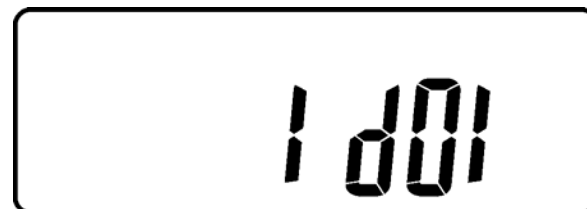

\* It shows UPS Identification Number.





Y



\* It shows the UPS is in the No. 1<sup>st</sup> of parallel systems.

3.5.1.17. Press scroll up  key pad, you may execute special functions. The Functions includes buzzer ON (as drawing Q1), or buzzer OFF (as drawing Q2, Alarm silence for UPS Warning) and self-test OFF (As drawing R1) or self-test ON. (as drawing R2. UPS will execute battery test for 10 seconds. If the self-test is successful, it will show as Drawing E1; otherwise, it will show as drawing E2 & error message in the same time.)

#### UPS Default Settings and their alternatives

- 3.5.1.18. Make sure the UPS is not "On" yet. Press On Switch  and scroll down  key pads simultaneously for approx. 3 seconds, the buzzer will sound twice, the LCD display screen shows as drawing Q1, then the UPS is under setting mode now.
- 3.5.1.19. To scroll down the LCD screen, you may refer to Chapter 3.5.1.16
- 3.5.1.20. Except Buzzer(as drawing Q1 & Q2) and Self-test(as drawings R1 & R2), all the rest default settings may be changed by pressing scroll up  key pad.
- 3.5.1.21. Drawings S1 and S2 mean the bypass input acceptable window, it can be 184Vac~260Vac or 195Vac~260Vac.
- 3.5.1.22. Drawing T means the bypass frequency window of the Inverter Output, the acceptable setting values are  $\pm 3\text{Hz}$  and  $\pm 1\text{Hz}$ .
- 3.5.1.23. Drawing U means the acceptable Inverter Output Voltage, of which voltage is 200Vac, 208Vac, 220Vac, 230Vac, or 240Vac.
- 3.5.1.24. Drawing V1, V2, V3 and V4 mean the operation modes of the UPS, of which alternative is Online, Eco(Economic) mode, fixed 50Hz Output or fixed 60Hz Output.
- 3.5.1.25. Drawing W means the adjustments of the Inverter Output, which may be calibrated as 0%, +1%, -1%, +2%, -2%, +3%, or -3%.
- 3.5.1.26. Drawing X means a specified address & position of the UPS when the UPS is in Parallel mode. The settable numbers are from 1st to 4th. The number must be 1st if the UPS is not in parallel.
- 3.5.1.27. Drawing Y means the parallel function status. The "P 01" means parallel function disabled and the "P 02" means parallel function enabled.
- 3.5.1.28. When all the setting changes are done, you have to press enter  key Pad to save all the changes when the LCD screen shows as drawing Z, then, the LCD screen will show as drawing AA to complete the setting changes. If you don't want to change those settings, you may press "OFF"  key pads for 5 seconds, then the LCD screen turns to Drawing AA directly, which means your setting changes are invalid.

Z

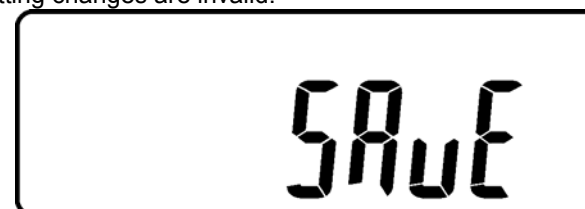

\* Please press Enter key to save data.





AA



\* It shows the UPS is locked.

- 3.5.1.29. Turn Off the breaker of Utility Input.
- 3.5.1.30. Your Setting changes are complete.



#### UPS Is Off Due to Unknown Reason and Its Trouble Shooting

- 3.5.1.31. If there is a serious abnormal condition occurred, the UPS will lock it itself in “OFF” position as shown in drawing AA and a abnormal message will show on the LCD screen.
- 3.5.1.32. After 3 seconds, all messages will be locked except Bypass messages(LED  & LCD ). In case the Utility is abnormal after the UPS is locked, the LED  will be extinguished and the LCD  will be shown on the LCD screen.
- 3.5.1.33. To release the UPS lock, please proceed the followings:
  - 3.5.6.3.1. Check those error messages recorded.
  - 3.5.6.3.2. Check to see Chapter 2.2 to trouble shoot the problem of the UPS. Otherwise, consult your local distributor for service.
  - 3.5.6.3.3. Press Off  key pad for 5 seconds and buzzer will sound twice.
  - 3.5.6.3.4. Turn Off the Breaker of Utility Input.
  - 3.5.6.3.5. The UPS lock problem is solved now, but you shall contact with your Local distributor to make sure the error message shown is solved.

#### Shut Off

- 3.5.1.34. Press Off  key pad for about 5 seconds, the Inverter output will be turned off, then the output load is supplied by Bypass loop and the LCD screen shows as drawing B.
- 3.5.1.35. Turn Off the breakers of Utility and Bypass Input.
- 3.5.1.36. The UPS is turned off completely.

#### Maintenance Bypass Mode

- 3.5.1.37. It is for UPS maintenance only. A Non-authorized technician is not allowed to operate the following procedures. If there is any damage under unauthorized condition, your warranty will be void immediately.
- 3.5.1.38. Press the Off  key pad for approx. 5 seconds, the LCD screen shows as drawing B and the UPS output is on bypass mode.
- 3.5.1.39. Release the cover of the CAM Switch(Maintenance Bypass Switch) first, then turn on the CAM Switch to “Bypass” mode, and at the right-hand upper Corner of the LCD screen will show  sign.
- 3.5.1.40. Turn off the UPS Utility breaker as well as Bypass Input Breaker, you then may proceed UPS maintenance now.
- 3.5.1.41. To repeat 3.5.1.4, you may put the UPS back to normal working mode, then turn back the CAM switch to “INV” mode, fasten back the cover and repeat 3.5.1.5 to 3.5.1.8 The UPS will switch back to inverter mode.
- 3.5.1.42. It is required to go through 3.5.1.38 first, then go through 3.5.1.39 If you skip 3.5.1.38, the UPS will alert for 10 seconds to warn that the procedure is abnormal, which may damage the UPS due to uncertain utility status. The UPS will switch back to Inverter mode immediately if you turn the CAM switch back to “INV”.



## 4. Troubleshooting Guide

### 4.1. Trouble Shooting

When the UPS malfunctions during operation, you may check the followings:

- a. Are the wirings of input and output correct?
- b. If the input voltage of the Utility is within the input window of the UPS?

In case problems or symptoms still exist, please proceed the followings for proper adjustment. Should the problem persists, please contact your local distributor for help.

Situation C	Check Items	Solution
UPS Red Fault LED lights up	<p>Check the error code shown on the LCD screen</p> <ol style="list-style-type: none"> <li>1. Er05,  &amp; </li> <li>2. Er06, Er10, Er12 Er28 &amp; </li> <li>3. EPO</li> <li>4. Er11, Er33</li> <li>5. Er14</li> <li>6. Er15</li> <li>7. Er16, Er27</li> <li>8. Er21</li> <li>9. Er24</li> <li>10. other error code</li> </ol>	<ol style="list-style-type: none"> <li>1. Check to see if the battery connection is properly done, then re-charge the batteries for 8 hours to see whether the UPS may backup normally; otherwise, consult your local distributor right away.</li> <li>2. If the CB3 is tripped, please turn off the UPS completely and keep the CAM switch at position INV before pressing CB3. Then remove some uncritical load at the UPS output end. If any damage of the coating of AC power cord, please replace a new one.</li> <li>3. Remove the short circuit occurred at the EPO terminal.</li> <li>4. Remove the objects blocked onto the ventilation holes.</li> <li>5. Check the cooling fans on rear panel are working normally.</li> <li>6. Make sure the UPS is operated normally. If it is on CVCF mode, you have to turn off and turn on the UPS again.</li> <li>7. All of parameters except ID Number in the parallel UPS must be same. Please refer chapter 0 to set them again</li> <li>8. Reconnect the RJ-45 wire or set a UPS with ID=1.</li> <li>9. When the UPS is on CVCF mode, it is prohibited to have bypass input. You have to turn off the UPS and bypass input and re-start the UPS.</li> <li>10. Consult your local distributor for help.</li> </ol>
UPS fails to offer battery backup or its back up time is shorter than its calculation.		If the backup time is still too short after 8 hours of charge, please contact your local distributor for battery replacement.
UPS locks itself and it can not be turned off.		Please refer to chapter 0 to trouble shoot the problem; otherwise, consult your local distributor for help.



## 5. Bundled Software Installation Guide

### 5.1. Hardware Installation

1. Connect the male connector of RS232 cable to the UPS communication port.
2. Connect the female connector of the RS232 cable to a dedicated RS232 port of the computer.
3. For optional interface cards, you may refer to Section 6 for installation.

### 5.2. Software Installation

Please refer to the user's manual of the software for installation.

## 6. Customer Options Slots

### 6.1. R2E (2nd RS-232 ) card

CN1 is for RS232 DB9.

For communication protocol, please refer to Chapter 0  
Installation Position: slot1(CHA-CN4) or slot 2(CHB-CN5).



### 6.2. RSE (RS-485) card

CN1 is for the function of the terminal resistor. Short pin1-2 to enable the function and short pin2-3 to disable it.

CN2 for RS485 and CN3 for remote power.

Definition

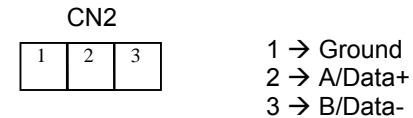

Installation Position: slot1.

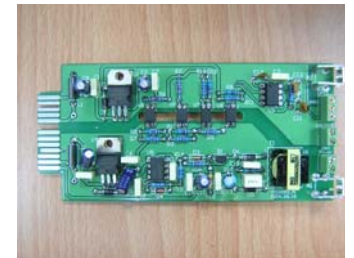

### 6.3. USE (USB) card

CN1 for USB.

Definition

- 6.3.1.1. Comply with USB version 1.0,1.5Mbps
- 6.3.1.2. Comply with USB HID Version 1.0.
- 6.3.1.3. The Pin Assignments of the USE card:



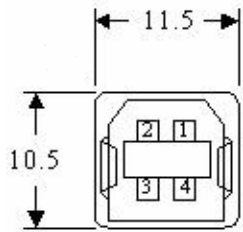

- 1 → VCC (+5V)
- 2 → D -
- 3 → D +
- 4 → Ground

Installation Position: slot1 ( CHA-CN3 ) or slot 2 ( CHB-CN4 ) .

#### 6.4. DCE (Dry Contact)-B card

The pin assignments of 10-Pin Terminal:

1	2	3	4	5	6	7	8	9	10
---	---	---	---	---	---	---	---	---	----

- Pin 1: UPS on Bypass mode.
- Pin 2: Utility Normal (Normal close contact)
- Pin 3: Utility Normal (Normal open contact)
- Pin 4: Inverter On
- Pin 5: Battery Low
- Pin 6: Battery Bad or Abnormal
- Pin 7: UPS Alarm
- Pin 8: Common
- Pin 9: Shutdown UPS positive(+ ) signal
- Pin 10: Shutdown UPS positive(- ) signal



The shutdown function will be activated, after a +6~+25Vdc is put between pin9 and pin10 for 5 seconds.

The capacity of each relay contact is 40Vdc/25mA.

Installation Position: slot1(CHA-CN7) or slot 2(CHB-CN8).

Flexible signal output for N.C.(Normal close) or N.O.(Normal open) contact by shorting pin1-2 or pin2-3 from JP1-5.

The shutdown function will be enabled in 1 minute after blackout occurs if the pin1-2 of both CN1 and CN6 be shorted by cap. Or, the shutdown function can only be enabled by pin9-10 of CN3 if the pin2-3 of both CN1and CN6 be shorted by cap. (Refer to 0)

#### 6.5. SNMP Cards

SNMP/WEB card

6.5.1.1. For installation, please refer to the user's manual attached with the card. .

6.5.1.2. In stallation

6.5.1.3. Po sition: slot 2(CHB).



Net Agent II Internal Card

6.5.1.4. For installation, please refer to the user's manual attached with the card.

6.5.1.5. In stallation

6.5.1.6. Position: slot 2(CHB).



**6.6. The Installation of those Interface Cards**

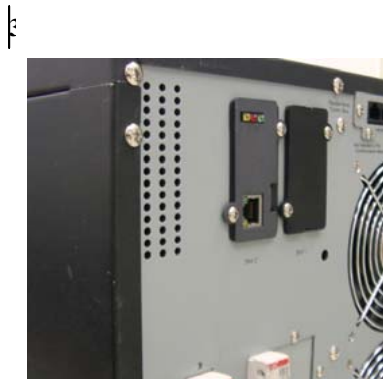

**7. Hot Swappable Battery Replacement**

1. Unscrew the bottom of the front panel as indicated in Step 1 as below.
2. Remove the front panel as indicated in Step 2.

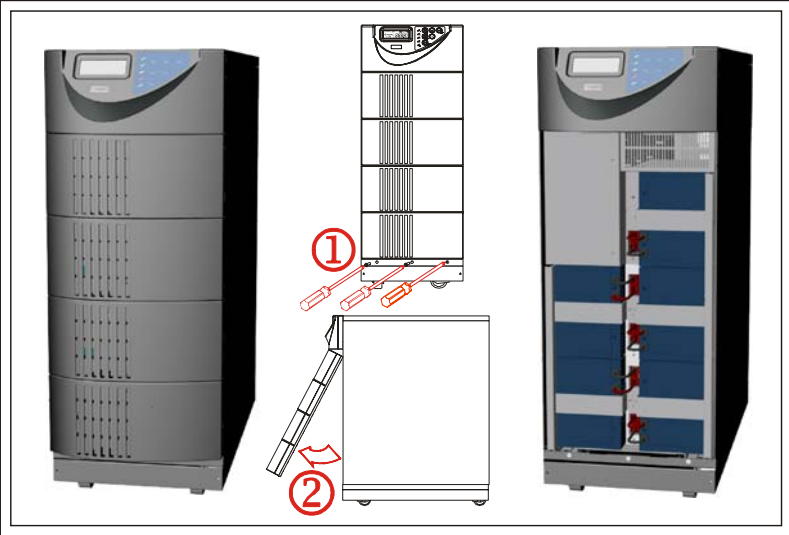

3. Remove the screw of the battery pack fastener as shown in Step 3.
4. Remove the fastener as shown in Step 4.
5. Unplug the hot swappable battery connectors as shown in Step 5.

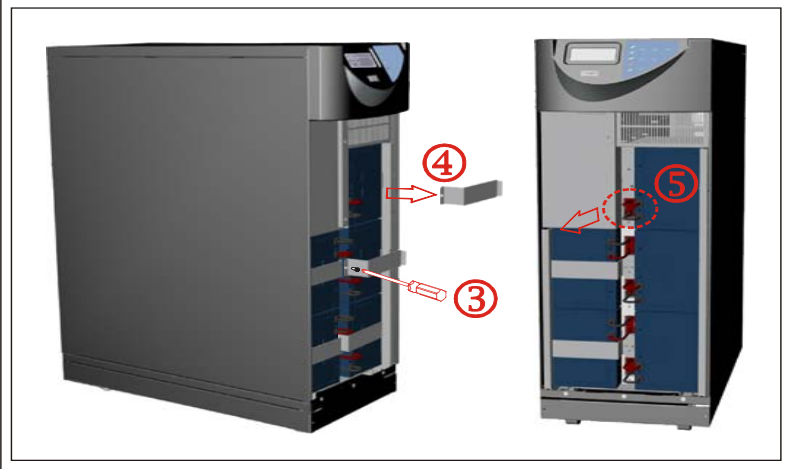

Turn the battery pack handle at 90 degree as shown in Step 6.  
 6. Remove the battery packs from the UPS as shown in Step 7.

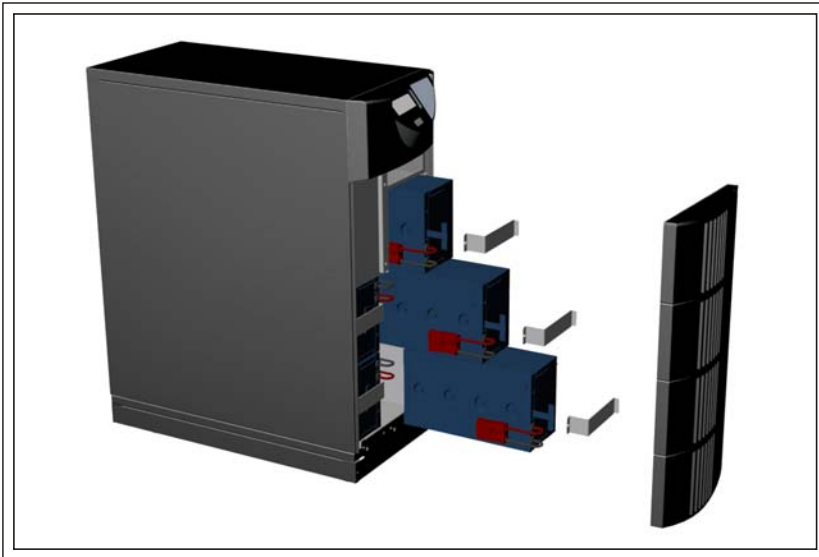

## 8. Specifications

Tower Models	SC60021T	SC60022T	SC80021T	SC80022T	SC11021T	SC11022T
--------------	----------	----------	----------	----------	----------	----------

### INPUT

Voltage Range	160 -280Vac					
Frequency	45 ~ 65 Hz					
Phase/Wire	Single, Line + Neutral + Ground					
Power Factor	Up to 0.99 at 100% Linear Load					
Current THD	<5% at 100% Linear Load					

### OUTPUT

Voltage	208/120Vac or 240/120Vac		208/220/230/240Vac		
Voltage Adjustment	+/- 0%; +/- 1%; +/- 2%; +/- 3%				
Voltage Regulation	+/- 2%				
Capacity 6000	VA/4200W	8000VA/5600W	10000VA/7000W		
Rated Power Factor	0.7 Lagging				
Wave Form	Sine Wave, THD < 3% (no load to full load)				
Frequency Stability	+/- 0.2% (Free Running)				
Frequency Regulation	+/- 1%				
Transfer Time	0ms				
Crest Factor	3:1				
Efficiency (AC to AC Nominal)	91%				
Efficiency (AC to AC ECO Mode)	Up to 97%		Up to 93%		
Leakage Current	< 3mA @ Full Load				
Manual Bypass Switch	Make – Before - Break				
DC Start	Yes				
Cooling	Variable Speed Fans (load determines speed)				

### DISPLAY, ALARMS, DIAGNOSTICS & COMMUNICATIONS

Status On LED + LCD	Line Mode, Backup Mode, ECO Mode, Bypass Supply, Battery Low, Battery Bad/Disconnected, Overload, Transferring with interruption & UPS Fault
Readings On LED + LCD	Input Voltage, Input Frequency, Output Voltage, Output Frequency, Load Percentage, Battery Voltage & Units Inner Temperature
Self-Diagnostics	Upon Power –on, Front Panel Setting & Software Control, 24 Hour self check
Audible Alarms and Visual	Line Failure, Battery Low, Transfer to Bypass, System Fault Conditions
Communications	RS232 Serial Port ( 2 slots available for optional SNMP/WEB, USB or Dry Contact Card)

### PHYSICAL

Input Connection	Hardwire and Cord with L6-30P Plug (Selectable)	Hardwire	
Output Connection	Hardwire		
Dimensions (HxWxD)	35" x 11.4" x 25.4"	35" x 11.4" x 25.4"	35" x 11.4" x 25.4"
Weight (l bs.)	176 2	76	280
Listing	UL1778; CE – FCC Class A		

### INTERNAL BATTERY

Battery Run Time @ Full Load	8	7	5
Type	Sealed Lead Acid Maintenance Free, 20 each 12V/7AH, 240V dc	Sealed Lead Acid Maintenance Free, 20 each 12V/9AH, 24 0Vdc	Sealed Lead Acid Maintenance Free, 20 each 12V/9AH, 240Vdc
Hot – Swap Batteries	Yes		
Recharge Time	4 hours to 90%		5 hours to 80%

*Extended Run Time Battery Cabinets	SC-BP6000T-2, SC-BP6000T-3, SC-BP1100T-2, SC-BP1100T-3 (Refer To Run Time Chart)
-------------------------------------	---

**COMMUNICATION Cards and Shutdown Software (Optional)**

SC-SNMP1	SNMP/WEB Network Card and Shutdown Software
SC-Contact/EPO	Dry Contact & EPO Card

Note: (2) slots available; both cards can be used simultaneously; RS232 Port is disabled when communication cards are installed.

**EXTERNAL EXTENDED BATTERY CABINETS (Optional)**

Model	SC-BP6000T-2 & -3	SC-BP1100T-2 & -3
Type	Sealed Lead Acid Maintenance Free, -2: 40 each & -3: 60 each 12V/9AH, 240Vdc	Sealed Lead Acid Maintenance Free, -2: 40 each & -3: 60 each 12V/9AH, 240Vdc
Hot – Swap Cabinets	Yes	
Battery Connection	Connector	
Dimensions (H x W x D)	29.5" x 11.4" x 25.4"	
Weight (lbs.)	326	

**EXTERNAL BATTERY CABINET CHARGER (Optional)**

SC-CHG-1000	1000W External Mount Battery Charger (1) charger per every (2) External Battery Packs Required	6.6"W x 11.1"D x 3.4"H	7 lbs.
-------------	--	------------------------	--------

**\*PARALLEL FOR CAPACITY/REDUNDANCY (4 Units maximum)**

SC-PKIT-2	Parallel Distribution Bypass 60Amp for (2) UPS Modules	10.5"W x 9.5"D x 3.7"H	11 lbs.
SC-PKIT-4	Parallel Distribution Bypass 120Amp for (4) UPS Modules	10.5"W x 16.4"D x 3.7"H	20 lbs.

\*Parallel for capacity configurations can use (1) battery system sized for the ultimate capacity.  
\* Parallel for redundancy configurations require (1) battery system for each UPS.

LIMITED WARRANTY FOR UniStar UNINTERRUPTIBLE POWER SUPPLY – DEPOT REPAIR OR REPLACE. This Warranty is given ONLY to purchasers who buy for commercial or industrial use in the ordinary course of each purchaser’s business: USA & Canada.

**General:**

Staco Energy Products Co. (“Staco”) products and systems are in our opinion the finest available. We take pride in our products and are pleased that you have chosen them. Under certain circumstances we offer with our products the following Warranty against Defects in Material and Workmanship. Warranty period is three (3) years from date of installation (max 42 months from ship date) for UniStar III, and two (2) year from date of installation (max 30 months from ship date) for UniStar P.

Please read your Warranty carefully. This Warranty sets forth our responsibilities in the unlikely event of defect and tells you how to obtain performance under this Warranty.

**Terms of Warranty:**

As provided herein, the Staco product is warranted to be free of defects in material and workmanship for a period defined above. If any part or portion of the Staco product fails to conform to the warranty within the warranty period, Staco, at its option, will furnish new or factory remanufactured part(s) for repair or replacement of that portion or part.

**Warranty Extends to First Purchaser for Use, Non-transferable:**

This Warranty is extended to the first person, firm, association or corporation for whom the Staco product specified herein is originally installed for use in the United States (the “User”). This Warranty is not transferable or assignable without the prior written permission of Staco.

**Warranty Claims Procedure:**

Within a reasonable time, but in no case to exceed sixty (60) days, after User’s discovery of a defect, User shall contact Staco Field Services at 1-866-261-1191. Subject to the limitations specified herein, nonconforming may be returned to Staco for repair or replacement, at Staco’s discretion, without charge for material or labor. All returns must be shipped freight prepaid to Staco Energy products Co. Staco will pay freight charges from factory to customer domestic (US and Canada) location. In the event that the nonconforming unit is not returned, User may be billed for new unit replacement cost.

**Items Not Covered By Warranty:**

THIS WARRANTY DOES NOT COVER DAMAGE OR DEFECT CAUSED BY misuse, improper application, wrong or inadequate electrical current or connection, inadequate water or drain services, negligence, repair by non-Staco designated personnel, accident in transit, tampering, alterations, a change in location or operating use, exposure to the elements, acts of nature, theft or installation contrary to Staco’s recommendations, or in any event if the Staco serial number label or tag has been altered, defaced, or removed.

THIS WARRANTY DOES NOT COVER return shipping costs, installation costs, circuit breaker resetting or maintenance or service items and further, except as may be provided herein, does NOT include labor costs or transportation charges arising from the replacement of the Staco product or any part thereof or charges to remove the same from premises of User.

REPAIR OR REPLACEMENT OF A DEFECTIVE PRODUCT OR PART THEREOF DOES NOT EXTEND THE ORIGINAL WARRANTY PERIOD.

**Limitations:**

- THIS WARRANTY IS IN LIEU OF AND EXCLUDES ALL OTHER WARRANTIES, EXPRESSED OR IMPLIED, INCLUDING MERCHANTABILITY AND FITNESS FOR A PARTICULAR PURPOSE.
- USER'S SOLE AND EXCLUSIVE REMEDY IS REPAIR OR REPLACEMENT OF THE STACO PRODUCT AS SET FORTH HEREIN.
- IF USER'S REMEDY IS DEEMED TO FAIL OF ITS ESSENTIAL PURPOSE BY A COURT OF COMPETENT JURISDICTION, STACO'S RESPONSIBILITY FOR PROPERTY LOSS OR DAMAGE SHALL NOT EXCEED ONE TIMES THE NET PRODUCT PURCHASE PRICE.
- IN NO EVENT SHALL STACO ASSUME ANY LIABILITY FOR INDIRECT, SPECIAL, INCIDENTAL, EXEMPLARY OR CONSEQUENTIAL DAMAGES OF ANY KIND WHATSOEVER, INCLUDING WITHOUT LIMITATION LOST PROFITS, BUSINESS INTERRUPTION OR LOSS OF DATA, WHETHER ANY CLAIM IS BASED UPON THEORIES OF CONTRACT, NEGLIGENCE, STRICT LIABILITY, TORT, OR OTHERWISE.

**Miscellaneous:**

- NO SALESPERSON, EMPLOYEE OR AGENT OF STACO IS AUTHORIZED TO ADD TO OR VARY THE TERMS OF THIS WARRANTY.
- Staco obligations under this warranty are conditioned upon system start-up by an authorized Staco service engineer and timely receipt of full payment and supersede all previous warranties. Staco reserves the right to supplement or change the terms of this Warranty in any subsequent warranty offering to User or others.
- In the event that any provision of this Warranty should be or becomes invalid and/or unenforceable during the warranty period, the remaining terms and provisions shall continue in full force and effect.
- This Warranty is given in and performance hereunder is to be construed under the laws of the State of Ohio.
- This Warranty represents the entire agreement between Staco and User with respect to the subject matter herein and supersedes all prior or contemporaneous oral or written communications, representations, understandings or agreements relating to this subject.

**International:**

Staco Energy Products Co. (Staco), Dayton, Ohio, warrants this equipment, with all applicable terms and conditions stated above, to be free of defects in material and workmanship for a period of one year from the installation date, no more than eighteen (18) months from shipment date from a Staco warehouse. For equipment physically located outside the USA or Canada this warranty covers defective parts only.

**003-2282 9/1/07**

## **ISE, Inc.**

1000 Royalton Rd.  
Cleveland, OH 44133 USA  
Tel: (440) 237-3200  
Fax: (440) 237-1744  
<http://iseinc.com>